

# Open-Architecture Router for Enlarging Network

Michihiro Aoki, Kentaro Ogawa, Takafumi Hamano, and Shinichiro Chaki  
NTT Network Service Systems Laboratories, NTT Corporation

{aoki.michihiro,ogawa.kentaro,hamano.takafumi,chaki.shinichiro}@lab.ntt.co.jp

## Abstract

The diversification of services has advanced in recent years. Therefore, network carriers request new services that they can provide as soon as possible. Carriers want to provide customized services, so they need a router to which new functions can be more easily added. We introduce a router for solving that requirement. The router uses an open architecture and standard interfaces. We call that an open architecture router (OAR) [1].

The traffic in IP networks has increased. The carrier wants to taking network stability and reducing maintenance cost in large-scale networks. We introduce a method for solving the requirements. The method uses distributed OARs in a network, and a consolidated control procedure reduces route computation.

## 1. Introduction

Recently, the diversification of IP services requires that economical routers have more flexible architectures than those of conventional commercial routers. A modular architecture that allows efficient and flexible routers to be constructed by assembling standard commercial hardware, software components, and interfaces is needed to satisfy the requirements.

Currently, many industry standardization activities for telecom equipment are being carried out. Those include the following standards defined by their respective organizations: the Advanced Telecom Computing Architecture (ATCA) standard [2] by the PCI Industrial Computer Manufacturers Group (PICMG) [3], the control and forwarding plane separation framework by the IETF Forwarding and Control Element Separation (ForCES) working group [4], line card configuration using an application program interface (NPF-API) by the Optical Internetworking Forum (OIF) [5], carrier-grade Linux (CGL) specification that achieves a high-reliability

operating system by the Open Source Development Labs (OSDL), and high-availability middleware using an API by the Software Availability Forum (SAF) .

The standard-based open-architecture router (OAR) is a leading candidate for an economical router with a flexible architecture.

For a more flexible, large-scale network, there is a method to separate control elements (CEs) from forwarding elements (FEs) in the network using like a softrouter architecture[6]. We are trying to use OAR to increase the scale of a network.

## 2. Configuration of Open Architecture Router

ATCA specification PICMG3.0 defines standards for form factor, shelf management, power, cooling distribution, and the backplane. A carrier-grade high-availability router is constructed using line cards (LCs), switch cards (SWs), and control cards (CCs) compliant with the ATCA specification.

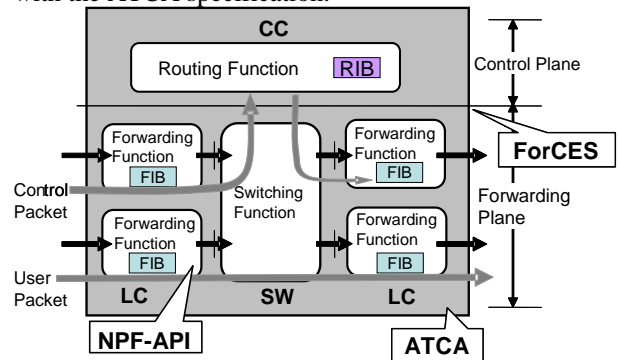

Fig. 1 Open architecture router model

The OAR is built with ATCA-compliant LCs, SWs, and CCs. The configuration is shown in Fig. 1.

Physical connections between each card are guaranteed using ATCA standard backplane interfaces. The CCs and LCs are configured based on the ForCES framework. By using the ForCES framework, independent adding and changing of functions are achieved for every LC and CC. The CC performs

control plane processing functions and the LCs perform packet-forwarding functions. One CC consolidates many LCs. The communication method between CC and LCs is also defined by the ForCES framework. When an LC receives a control packet, the LC sends the packet to the CC via an SW using the ForCES communication method. The CC constructs a routing information base (RIB), commonly called a routing table, by performing routing protocol processing based on the received control packet. Accordingly, the CC modifies every LC's forwarding information base (FIB), commonly called a forwarding table, using the ForCES communication method. The LC performs packet forwarding by looking up the FIB and QoS control functions. The LC needs to be configured for flexibility and high-speed packet forwarding. Therefore, an LC is constructed using a network processor and LC configuration is performed by using NPF-APIs. In addition, the CC needs to have high availability. Hence, a carrier-grade OS, such as CGL made by OSDL, and high-availability middleware using SAF-APIs are used for the CC. Moreover, application software that processes the routing protocol is installed on a CC. The application software supports LC's FIB configuration using NPF-APIs.

### 3. Open-Architecture Router for Enlarging Network

We are trying to increase the size of networks using OAR, as shown in Fig. 2. The router is composed of separate control elements (CEs) and forwarding elements (FEs) in a network. In this model, CE corresponds to CC, and FE corresponds to LC in Fig. 1. A network element (NE) is composed by the binding of one or more CEs with one or more FEs. The binding phase of FE and CE is provided in a pre-association phase in ForCES. In the pre-association phase, there is a binding procedure between FE and CE. A specific mechanism is not provided. After the binding of FE and CE is completed, a post-association phase is provided. In the post-association phase, the setting data for the data-plane processing such as the routing table, QoS parameters, and access filters are set at the FE by the CE. The format of the ForCES protocol message is being standardized now. Multiple FEs can correspond to one CE at the same time for the mapping of FE and CE. In consolidating control-plane architecture, path control is achieved by the server calculating all routes and setting the result in the routing table of the router. Therefore, the route exchange processing and the route

calculation processing functions become unnecessary in the router.

Moreover, service elements (SEs) are placed in the new service function. This is a function in which the service processing (for example, security and access control) is executed and processed by execution demands made by FEs and CEs. The number and capacity of CEs and SEs are increased according to processing demand.

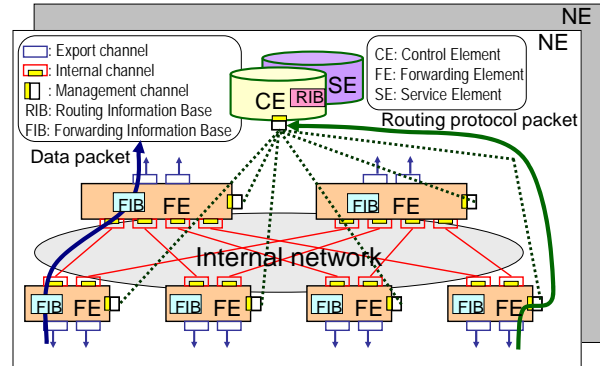

Fig. 2 Network enlargement model

### 4. Conclusion

In this paper, we introduced the OAR and methods for enlarging networks using OAR. We have several problems such as difficulty of adding new functions, instability of routing protocols on large scale network. We think that the introduced method is one of the candidate techniques for a carrier network to solve the problems.

### Acknowledgements

A part of this research project is supported by the National Institute of Information and Communications Technology (NICT) of Japan.

### References

- [1] M. Aoki, et al, "ATCA-Based Open-Architecture Router Prototype," IEICE, Vol.E89-B, No.5 May. 2005.
- [2] ATCA (Advanced Telecom Computing Architecture) <http://www.picmg.org/newinitiative.stm>
- [3] PICMIG (PCI Industrial Computer Manufacturers Group) <http://www.picmg.org/>
- [4] ForCES (Forwarding and Control Element Separation) <http://www.ietf.org/html.charters/forces-charter.html>
- [5] OIF (Optical Internetworking Forum) <http://www.oifforum.org/>
- [6] T.V. Lakshman, T. Nandagopal, R. Ramjee, K. Sabnani, and T. Woo, "The softrouter architecture," Proceedings of ACM HotNets-III Workshop, San Diego, CA, Nov. 2004.